

Title: Project of Micro-Satellite Constellation for Earthquake Precursor Study

Primary Point of Contact (POC) & e-mail: Prof. Masashi Kamogawa, kamogawa@u-gakugei.ac.jp

Co-authors: Kohei Tanaka, Kento Nakazawa, Kaori Mochizuki, Junichi Takisawa, Kikuko Miyata, Hideki Kayaba, Takatoshi Morinaga, Kiichiro DeLuca

Organization: Tokyo Gakugei University & Keio University

We apply to Student Prize.

Need

A mitigation of the disasters attributed to mega-earthquake should be prioritized for a human life. In order to promote an earthquake prediction, we statistically verify two plausible ionospheric precursors and conclude their existences. In this study, successive micro-satellite constellation is operated for more than 11 years exceeding one solar cycle. For the development of many satellites, a number of countries which are mainly a member of UNISEC are encouraged to join this project. In addition, the concept of semi- open source is employed to supply the satellite technology for participating countries and educate the developing countries.

Mission Objectives

1) Promotion of earthquake prediction research and earthquake precursor

A mitigation of huge disasters caused by mega-scale earthquake such as 2011 M9.0 Tohoku earthquake is the most important for human life. The prevention and the prediction of the disaster play a major role in the mitigation. The technology of the prevention is remarkably developing and is widely used in our life, while even the modern seismology does not conclude that the earthquake is predictable or not. Therefore, it is extremely difficult to predict the earthquake a few hours to a few days before the mainshock, termed the short-term prediction (*Geller, 2011*). Meanwhile, a number of various precursors have been reported through the various measurements. In particular, ionospheric precursors have been reported since the 1980s. Such a precursor is undoubtedly useful and practical for the short-term earthquake prediction if the correlation or causation between the precursor appearance and the earthquake occurrence is quantitatively proven. However, most of the reports claimed that one regarded anomalous phenomena before the mainshock as a precursor without sufficiently considering the anomalous phenomena during the aseismic period, which means insufficient scientific discussion in the statistical point of view. In addition, the scientists engaging in this work excessively demonstrate their achievements in the commercial media frequently before publishing the scientific papers. Since such a situation resembles a tumult about a cold fusion, the precursor science is severely criticized as a “pathological science” (*Geller, 1999*). However, we carefully investigated a number of ionospheric precursors reported from the scientific papers and concluded that a few ionospheric precursors are plausible and statistically evaluable (*Kamogawa, 2006*). In this proposal, thus, we focus on the plausible ionospheric precursors and monitor the ionosphere by our proposed micro-satellite. Finally, we elucidate the physical mechanism.

2) Detection of earthquake precursor by the satellite and statistical verification

It is difficult to statistically verify the causality between precursor phenomena and large earthquake in the ground-based observation. One of the reason is that very long period, more than the order of 10000 years, is required to obtain the statistically significant event number, namely at least 100 of the nearby earthquake with the magnitude more than 7.0 (hereafter $M \geq 7.0$), although the world wide seismicity of $M \geq 7.0$ have around 10 events per a year. When we address the ionospheric precursors through the satellite observation, many events of large

earthquakes can be encountered. According to *Kamogawa* (2006), the lead-time and the duration of the precursor range from a few hours to a few days. Therefore, the ionospheric precursor is detectable because they are longer than the period of one satellite orbit. It is highly expected that more than 100 $M \geq 7.0$ earthquakes would be encountered during more than 10 year observation. Moreover, the continuous observation during more than 10 years corresponding to one solar cycle is also required to discriminate the variation generated by magnetic storm, i. e. the major variation in the ionosphere.

3) Target precursor and verification procedure

According to our review of ionospheric precursor papers (*Kamogawa*, 2006; *Uyeda et al.*, 2011), a pre-seismic decreased intensity of VLF (very low frequency) electromagnetic waves (*Němec et al.*, 2008) and a pre-seismic depletion of ionospheric electron density (*Liu et al.*, 2006) are plausible precursors for the earthquake prediction. The former is the statistical results for global earthquakes which are obtained by the DEMETER satellite launched by CNES, France, on June of 2004. The latter is also the statistical results for Taiwan earthquake which is obtained by the ground-based GPS measurement. Both the results showed the statistical significance of a few hundred $M \geq 5$ earthquake. If such a precursor is a true precursor of earthquake and practical for the earthquake prediction, a clearer anomaly should appear in the $M \geq 7$ earthquakes of which energy has 1000 times larger than that of $M 5$ earthquake. In the epidemiology that statistically infers the causality, this view of comparison is important according to Hill's criteria (*Hill*, 1965). In order to detect the ionospheric precursor, we employ a standard method of ionospheric research and construct an empirical ionospheric model. The model is constructed with measured data and provide the standard values and deviation as a function of longitude, latitude, local time, solar flux (EUV), and Kp index. We judge anomalies when the observed value exceeds a certain threshold derived from the model.

4) Semi- open source and education for satellite design

Continuous operation of satellite constellation is prioritized to achieve this project. Hence, we encourage other countries, mainly a member of UNISEC, to share common understanding of earthquake prediction and join this project. In the project, we reduce satellite cost by following the satellite design and technical know-how of UNITEC. We, then, produce the prototype satellite and operate it. This design and product would be semi- open source for participating countries and the data and result would be also shared. In particular, this work becomes an educative satellite design as well.

5) Financial source: Relief donation for future and official development assistance (ODA) in Japan

Nowadays earthquake relief donation is widely popularized to many countries. The donation culture for the disaster victim is expected to grow further. In general, the earthquake relief donation is for the past affairs. In this project, however, we introduce the earthquake donation for future mitigation of disaster and anxiously ask people to support our project. Moreover, we supply our satellite design under the concept of semi- open source to developing countries with the support of official development assistance (ODA) in Japan, because Japanese government started the official development assistance for the space development.

Concept of Operations

1) Three sensors for monitoring

In order to statistically verify two plausible precursors, electromagnetic wave measurements (1-1 and 1-2) for

Němec et al. (2008) and electron density and temperature measurements (1-3) for *Liu et al.* (2006) are carried out.

1-1. Electric field measurement (EFM)

Three components of electric field of VLF-band electromagnetic waves are measured. We employ dipole antennas (1.0 m) which are the similar instrument to ICE (Instrument Champ Electrique) embedded in DEMETER satellite (*Berthelier et al.*, 2006).

1-2. Magnetic field measurement (MFM)

Three components of magnetic field of VLF-band electromagnetic waves are also measured to confirm electric field measurement, although *Němec et al.* (2008) used only electric field data measured by the DEMETER. For the measurement, magneto-impedance (MI) sensor (*Mohri et al.*, 2002) of which size is a few millimeter cubic box is onboard. The MI sensor will be adopted by RISESAT of Tohoku University, Japan. The MI sensor connected with a non-magnetic boom is installed 60 cm meter away from the satellite.

1-3. Electron density and temperature measurement (EDTM).

In-situ measurement of electron density and temperature is carried out with Langmuir probe. We adopt the same instrument of ISL(Instrument Sonde de Langmuir) of DEMETER (*Lebreton et al.*, 2006).

2. Data acquisition and transfer

Measured data is recorded in SD card. The sampling of EFM, MEM, and EDTM is 1 Hz. In EFM and MEM, 1 Hz data is spectrum data from 0.1kHz to 20 kHz with 0.1 kHz and 16 bit resolutions. In EDTM, one sweep lasts for 0.1 second, and the mean of 10 sweep data is used for 1 Hz data. Time and location of the satellite are obtained from GPS receiver. Total amount of one-day data reaches 500MB before the compression. Measured data and operation data transfer to a ground receiver through X- band and S- band, respectively. This design follows Hodoyoshi-3. In the current system, one ground receiver on the ground is needed. Some of participating countries also install the receivers, which contributes to more stable downlink.

3. Satellite bus system

Satellite bus system is simply designed for the developing countries to easily accomplish the construction. The design concept, therefore, is simple configuration: For example, the complicated redundancy technique is omitted because the number of I/F is reduced. Furthermore, the I/F of power and communication lines between components are unified, so that each country can update the system with considering their idea.

Space Segment Description

From mission requirement, this satellite needs to 1) have high accuracy attitude determination ability, 2) orbit data acquisition ability (~1 km) and 3) treat large volume mission data. Since the spatial scale of these precursors is around a hundred kilometer, 1 Hz sampling (~ roughly 10 km spatial resolution) and 1/60 radian altitude determination ability are required. Since total power consumption of three sensors is very low (6W), the solar cells of this satellite are body mounted. Figure 1 shows the system diagram.

This satellite consists of the following two main parts: Satellite bus system and mission payload system as shown in Figure2. The satellite bus system consists of Electric Power System (EPS), Communication (COM) and Attitude Determination and Control System (ADCS). EPS consists of SAP, PCU, BAT and Heater. To determinate

the attitude, we have two star trackers, a FOG and 6 sun sensors. GPS receiver gains orbit data. The satellite attitude is controlled by one wheel and three orthogonal magnetorquers. This satellite has 2 communication frequency bands to separate the mission data line and house-keeping (HK) data line. We choose X-band for mission and S-band for HK data.

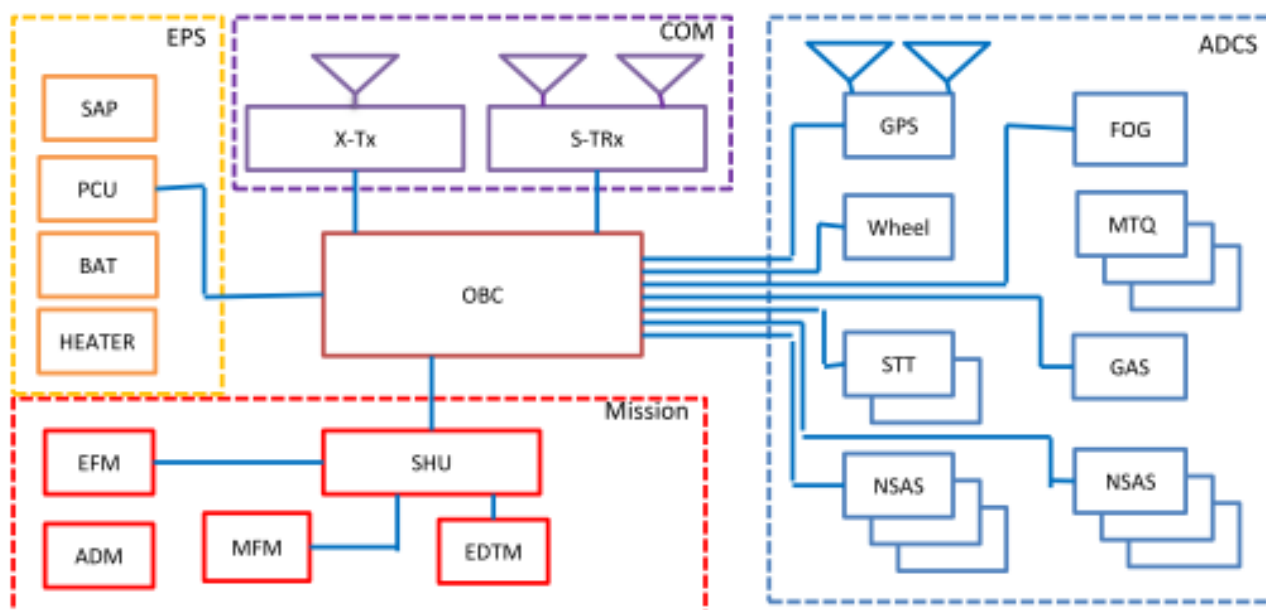

*SAP: Solar Array Panel, PCU: Power Control Unit, BAT: Battery, HEATER: Heater, OBC: On-board Computer, Wheel: Wheel, GPS-R: GPS-Receiver, X-Tx: X-Transmitter, S-TRx: S-Transmitter & Receiver, MTQ: Magnetic Torque, STT: Star Tracker, GAS: Geomagnetic Acquisition Sensor, NSAS: Nonspin-type Sun Aspect Sensor, FOG: Fiber Optical Gyro, SHU: Science Handling Unit, EFM: Electric field measurement, MFM: Magnetic field measurement, EDTM: Electron density and temperature measurement, ADM: Antenna Deployment Mechanism

Figure 1 System Dialog

Orbit/Constellation Description

The satellite constellation consists of at least two satellites of which orbits are sun-synchronous and non-sun-synchronous, respectively. The former is to construct high quality standard ionospheric model at a certain local time because the number of parameter is reduced. The latter is to construct the whole-covered standard ionospheric model by interpolating the data measured by the non-sun-synchronous satellite and to investigate the physical model of the observed precursor through considering global ionospheric condition. As the same reason of reducing the parameter, our target altitude of satellite is around 600 km, and we only apply this altitude as a piggyback. Moreover, we try successive satellite launching to continuously keep the measurement before the satellite becomes out of operation. Note that in successive launching for sun-synchronous satellite the local time should keep the same as the previous one.

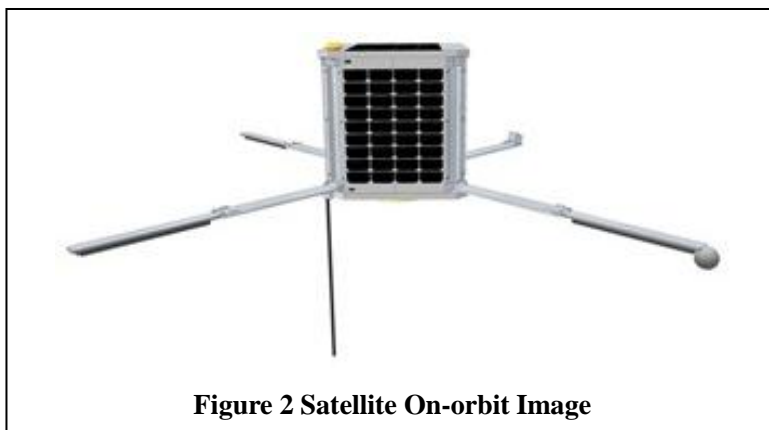

Figure 2 Satellite On-orbit Image

Implementation Plan

In Japan, the government has provided tremendous financial support for an earthquake prediction research. Most of support is for fundamental seismology, geodesy, and long-term (a few decade years) prediction. A research of short-term prediction which is most important for the disaster mitigation is barely assigned (Uyeda *et al.*, 2009). According to an earthquake research committee under the Japanese government, the precursor research is out of their future plan. It is consequently impossible to be supported with budget of earthquake prediction research in Japan. Therefore, we must find other financial source, and then propose the following ideas.

1) Establishment of newly donation

As summarized above, nowadays earthquake relief donation is widely popularized to many countries. The donation culture for the disaster victim is expected to grow further. In general, the earthquake relief donation is for the past affairs. However, we propose the earthquake donation for future mitigation of disaster. In this project, we grow this idea to various societies and anxiously ask people to support our project.

2) Japanese ODA for developing countries

Recently, developing countries especially in Asia enthusiastically desire to develop their own space technology. Coincidentally, Japanese government started the ODA for the space development, of which the first case is 500 million US\$ support for Vietnam. Since our proposed “semi- open source” for the satellite design produces educational materials, our proposal agrees with the ODA’s philosophy. Therefore, we try to find this financial source from the ODA project.

References

- Geller, R. J. (1999), Earthquake prediction: is this debate necessary?, *Nature debates*, http://www.nature.com/nature/debates/earthquake/equake_1.html.
- Geller, R. J. (2011), Shake-up time for Japanese seismology, *Nature*, **472**, 407–409, doi:10.1038/nature10105.
- Kamogawa, M., (2006) Preseismic Lithosphere-Atmosphere-Ionosphere Coupling, *Eos Trans. AGU*, **87**, 417 & 424.
- Uyeda, S., T. Nagao and M. Kamogawa, (2011) Earthquake Prediction and Precursor, *Encyclopedia of Solid Earth Geophysics*, Part 5, 168-178, DOI: 10.1007/978-90-481-8702-7_4, Springer.
- Němec, F., O. Santolík, M. Parrot, and J. J. Berthelier (2008), Spacecraft observations of electromagnetic perturbations connected with seismic activity, *Geophys. Res. Lett.*, **35**, L05109, doi:10.1029/2007GL032517.
- Hill, B. A. (1965), The Environment and Disease: Association or Causation?. *Proc. Royal Soc. Med.*, **58**, 295–300.
- Berthelier, J.J., et al. (2006), ICE, The electric field experiment on DEMETER, *Planetary Space Sci.*, **54**, 456-471.
- Mohri, K., et al., Amorphous wire and CMOSIC-based sensitive micro-magnetic sensors (MIsensor and SIsensor) for intelligent measurements and controls, *J. Magnetism Magnetic Materials*, **249**, 351–356.
- Lebreton, J. -P., et al. (2006), The ISL Langmuir probe experiment processing onboard DEMETER: Scientific objectives, description and first results, *Planetary Space Sci.*, **54**, 472-486.
- Uyeda S., T. Nagao, M. Kamogawa, (2009) Short-term Earthquake Prediction: Current Status of Seismo-Electromagnetics, *Tectonophys.*, **470**, 205-213, doi:10.1016/j.tecto.2008.07.019.